

BlueDiamond®

condensate removal pumps

MicroBlue®

With no additional silencing accessories required, not only is the MicroBlue® a silent running pump but it can also be mounted in any orientation whilst operating both wet and dry continuously. The MicroBlue® is a dual voltage pump which uses proven thermistor level sensing technology to remove the risk of stuck or sunken float switches.



Fascia Kit
(T18-016)

Ducting Kit
(X85-507)

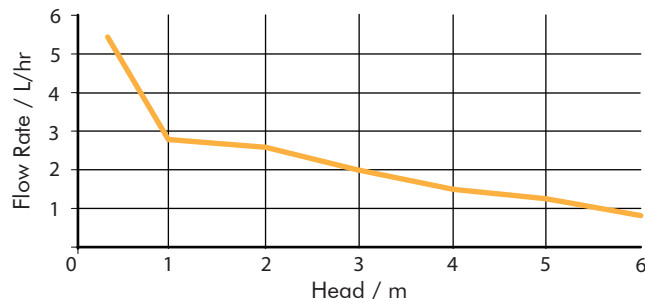

Performance

17dba

Max flow	Max head	Max suction lift
5 litres/hour	5 metres	2 metres

Sensing Options

Reservoir sensor

X85-001 (HLA PACK)



MicroBlue® pump available with:

Ducting Kit

X85-507 (HLA PACK)



Fascia Kit

T18-016
(Pump not included)



Dimensions (mm)

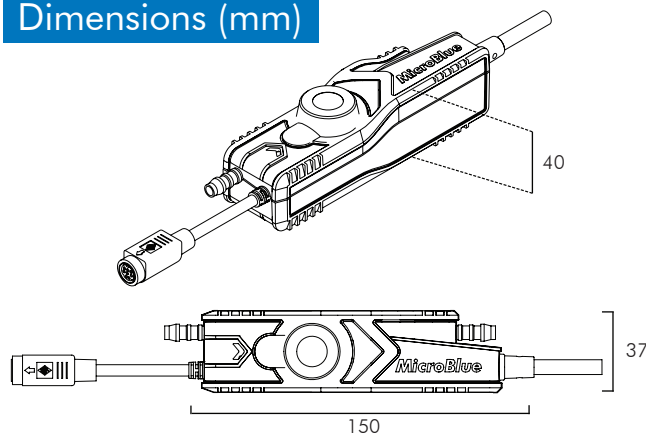

Installation Options

The MicroBlue® can be mounted in any orientation up to 2m away from the air conditioning unit.

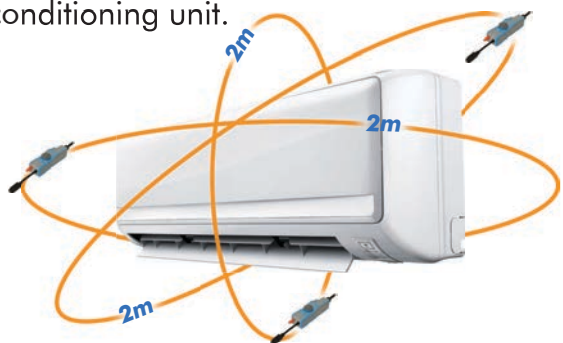

Fail safe alarm (FSA), a volt free relay designed to switch the AC unit off, but leaves the pump running continuously when the condensate reaches a critical point in the reservoir.

High Level Audio (HLA), is an integral audio and visual alarm. When the condensate is at a critical point with-in the reservoir the diagnostic light in the pump will switch from green and will start to flash red with a 2 beep warning every minute. The pump will continue to operate while in alarm mode

