

BlueDiamond®

condensate removal pumps

MultiTank®

The MultiTank is favoured among architects and design consultants and is available for using with either MegaBlue® or MaxiBlue® pumps. The tank incorporates an energy efficient solid state level sensor which eliminates the use of moving floats - which often become stuck. By manifolding a number of fan coil units into the 1.5L MultiTank, it offers the installer complete flexibility surrounding any multi-unit installation.



3 year
warranty

Revolutionary Sensory Technology



With no moving parts the MultiTank offers a reliable alternative to stuck or sunken float switches. Incorporating our patented and proven thermistor technology the hi-low solid state level sensor only runs the pump when condensate is produced. With no moving parts to become clogged or stuck it is an ideal alternative to existing float switches.

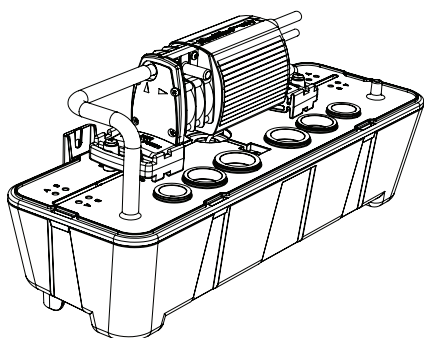

Option 1: MultiTank with MaxiBlue® - 3.7 g/hr

Designed for high lift applications (26.24ft) the MultiTank and MaxiBlue® make an ideal combination. Quiet enough for ceiling mounting and powerful enough for remote location makes a wide variety of installation possibilities a lot faster and simpler.

Dimensions (mm)

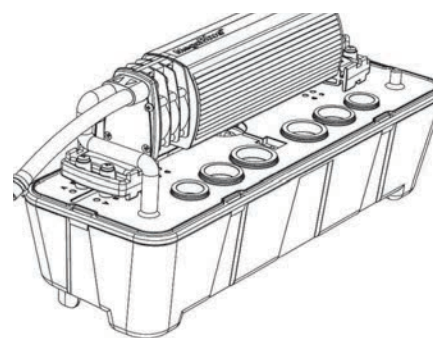
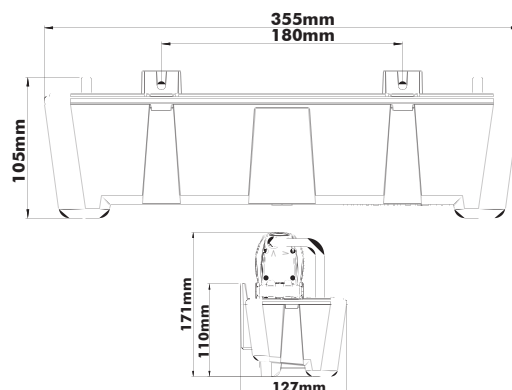

Option 2: MultiTank with MegaBlue® - 13.2 g/hr

Offering exceptional performance the MegaBlue® can remove condensate far away and fast. With a head of 66.5ft (6 storeys!) the MultiTank with MegaBlue® can be used as a remote central collection point for condensate drainage.